



neaco

norton engineering alloys co ltd

neaco genesis range

Genesis

access and safety...

The high performance balustrade, rails, access walkways and roof safety systems of the Genesis range provide solutions for every need and budget. Genesis products are durable in the most demanding environments, from the atmospheric conditions of factories, chemical plants and water treatment works to the harsh exposure of lighthouses and rooftops.

The Genesis range features environmentally friendly design with modular construction that minimises noise, waste and energy consumption. Each application is versatile and adaptable, strong and maintenance-free. Handrails are engineered for a smooth finish with tactile comfort and Techdek aluminium open grille walkways are lightweight yet durable with high slip resistance for secure footing.



Genesis - a unique range of benefits and applications

- Fast installation
- Fully recyclable with high residual value
- Corrosion-free
- DDA compliant
- Available as mill finished or powder coated
- Balustrade and safety railing
- Industrial guard rails
- Roof edge protection
- Standing-seam roof edge protection
- Access walkways
- Mezzanine floors
- Ventilation grilles



...for **urban** and
industrial landscapes

Genesis

rail systems

industrial



guardrails or barriers

- 38mm diameter top rail
- An easy-to-assemble and cost-effective solution
- Up to 1.7 metre stanchion centres
- Suitable for a wide variety of environments



mechanical fixings do not require adhesive



mechanical fixings to all connections



versatility/adjustability/flexibility



infill options available

Available as supplied only or supplied and installed.

r2r ramp to rail



strong and adjustable



functional and fast to fit



mill finished...



...or a coated top rail



- 50mm diameter top rail
- A highly adaptable ramp handrail system
- Up to 2 metre stanchion centres
- Provides finished materials to site within just 4 weeks of order details



great looks that meet the budget

modular handrail components...

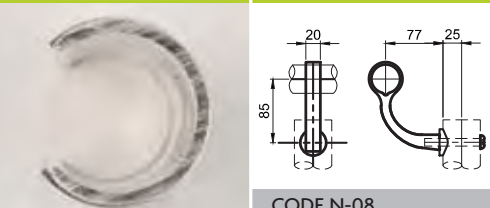
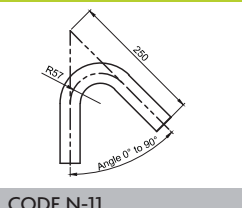
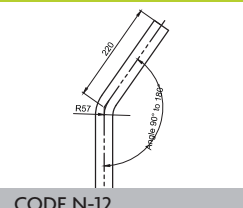
Components available for 38mm diameter handrails and 50mm diameter stanchions.

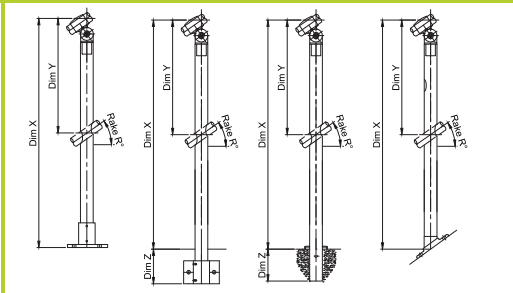
<p>Stanchion Tee</p>  <p>CODE N-01</p>	<p>Stanchion Elbow</p>  <p>CODE N-02</p>	<p>Stanchion Raked Tee</p>  <p>CODE N-03</p>	
<p>Rail End Cap</p>  <p>CODE N-06</p>	<p>Split Connecting Ferrule</p>  <p>CODE N-07</p>	<p>Offset Bracket</p>  <p>CODE N-08</p>	
<p>Acute Pulled Bend</p>  <p>CODE N-11</p>	<p>Obtuse Pulled Bend</p>  <p>CODE N-12</p>	<p>Rectangular Flat Base</p>  <p>CODE N-13</p>	
<p>Heavy Duty Side Palm</p>  <p>CODE N-16</p>	<p>Raked Rectangular Base</p>  <p>CODE N-17</p>	<p>Grout Base Collar</p>  <p>CODE N-18</p>	
<p>Genesis Industrial horizontal stanchions</p>			<p>raking stanchions</p>
			
<p>CODES Typically: Dim X = 1100mm Dim Y = 550mm Dim Z = maximum 200mm</p>		<p>R1 R2 R3 R4 Dim X, Y & Z to be stipulated by customer</p>	

...for the urban and industrial landscape

Wall Bracket		Wall Fitting	
90° Cast Bend (small)		90° Pulled Bend (large)	
Heavy Duty Flat Base		Rectangular Side Palm	
Stanchion End Cap		Hand Rail Tube	
Stanchion End Cap		Complete D Bend	
			Dim Y = between 300mm and 600mm (typically matches Dim Y of horizontal stanchion) Specify- Horizontal or Raked (Dim Y = 300mm to 600mm)

Genesis Industrial with Grille Infill



Genesis Rail System

specification

- Mill Finish aluminium alloy extrusion to BS EN 755-9: 2008
- Aluminium LM6 pressure die castings
- Manufactured in accordance with the recommendations of BSEN 14122-3: 2001
- A fully compliant modular system comprising:
 - 38mm - 50mm diameter top rails in 3.25mm wall tube
 - 50mm diameter stanchions in 6.35mm wall tube
- Carefully designed components for ease of assembly utilising mechanical fasteners

- Smooth top rail connections to provide smooth and tactile comfort
- Powder coated rail option available for visual contrast
- Infill options available
- Optional kicking plates available
- Fixings can be supplied on request
- Rail systems to suit 0.3 kN/m load have been fully tested in accordance with BSEN 14122-3:2001
- Rail systems to suit 0.36 kN/m and 0.74 kN/m loads have been tested in accordance with BS 6180:1999
- Corrosion-free
- Maintenance-free, lightweight, strong and flexible
- 1/3 of the weight of steel for easy installation and manoeuvring
- Satisfies Fire Officer Requirements
- Fully recyclable
- Structural fixings are not included. If these are required please specify type. These can be supplied at additional cost.
- Bespoke designs available on request at additional cost. To discuss your individual requirements please call our team on 01653 695721.

The following table provides the typical maximum centres for 1100mm high balustrade with either our grout in or top fixed base.

Side Fixings applications will reduce these centres depending on the fixing positions and increased stanchion height.

Maximum Stanchion Centres (in mm)			
	Side Loading		
Balustrade System	0.3 kN/m	0.36 kN/m	0.74 kN/m
Industrial 38Ø Toprail	1700	1600	1100
r2r 45Ø Toprail	1900	1750	1100
r2r 50Ø Toprail	2000	1850	1100

These are the maximum centres based upon ideal conditions
Please Note: 1.5kN/m loading is available on request

Techdek Walkway Systems

specification

Genesis Rail Systems are superbly complemented by our range of Techdek aluminium open grille walkways which provide similar qualities:

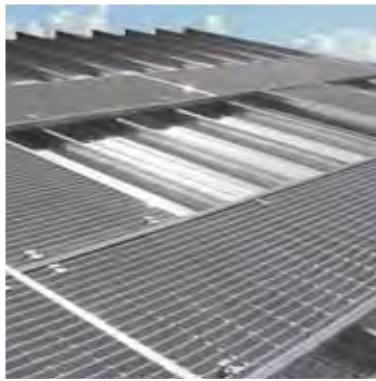

- Maintenance-free durability
- Corrosion-free
- Non-toxic and non-combustible
- 100% recyclable
- $\frac{1}{3}$ weight of steel

The following pages provide comprehensive specification and technical information.



Panel Terminology

- A Load-Bearing Bar**
The load-bearing member spanning between supports.
- B Swage Bar**
A square bar that passes through the load-bearing bar that is swage locked at right angles to the load-bearing bars providing lateral restraint.
- C Length (direction of span)**
The overall dimensions of a flooring panel measured parallel to the load-bearing bars.
- D Width**
The overall dimension of a panel measured at right angles to the load-bearing bars.
- E Banding**
A bar or section welded to the edges of a flooring panel, generally flush with the top and bottom of the load-bearing bars. The banding can be straight or curved.
- F Kicking Plate (Toe Plate)**
A flat bar around the edge of a flooring panel and projecting above the top of the load-bearing bars.
- G Cut-outs**
The area removed to allow obstructions to pass through the panel.
- H Pitch**
The distance from centre-to-centre of the load-bearing or swage bars.
- I End Plate**
A fixed plate on a stair or ladder tread for attaching to the stringer.
- J Tread Nosing**
A member attached to the front of a stair tread or to a flooring panel.
- K Serration**
Curved notches cut into the top surface of the load-bearing bars providing slip resistance across the whole surface.
- L Clearances**
The gap between panels or adjoining structures.
- M Extended Swage Bars**
The swage bars on one panel are extended so that the flooring appears to be continuous when viewed from top or bottom.

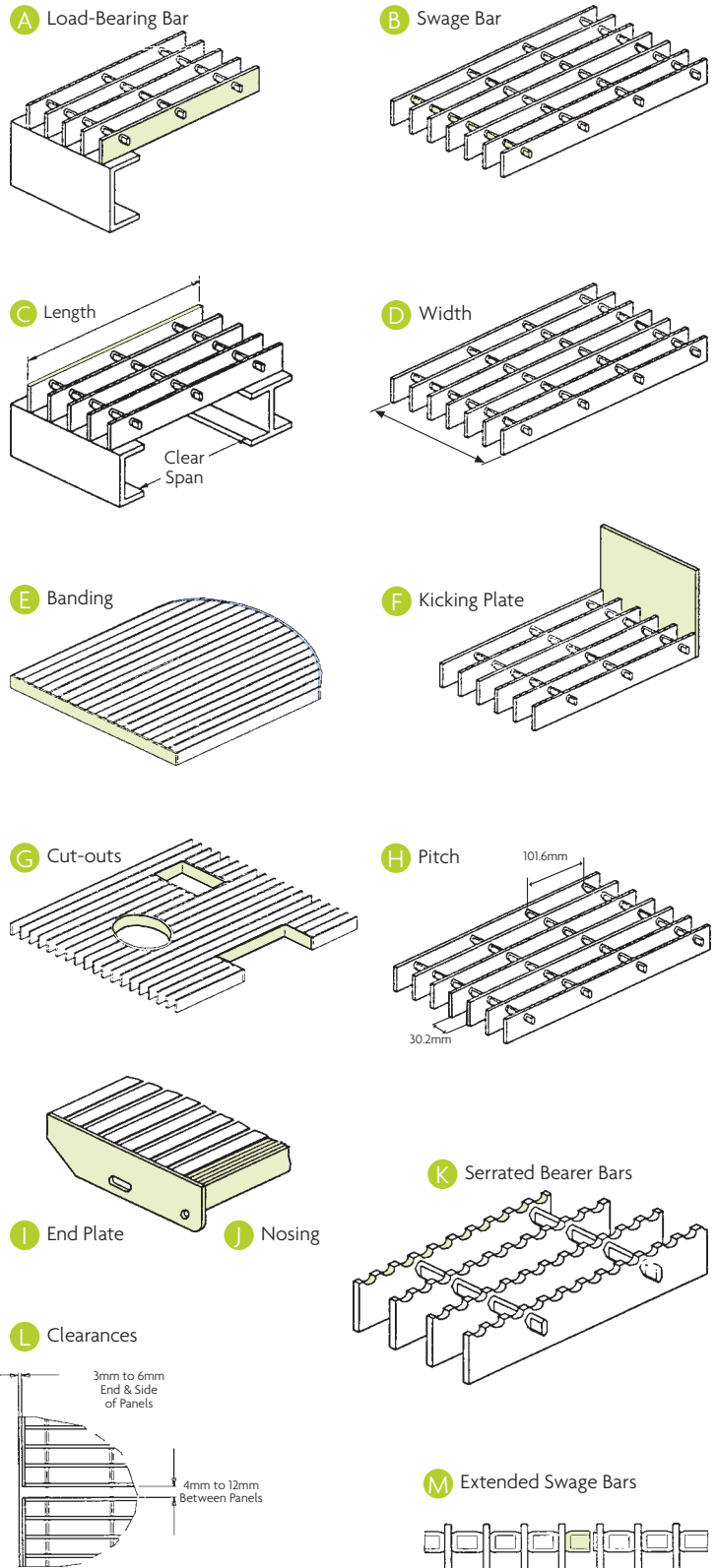

Techdek Walkways

Panel range/ Surface options

NEATDEK

- A** 5mm GAP RIBBED NEATDEK
Designed for pedestrian comfort
- B** 8mm GAP PLAIN NEATDEK
- C** 8mm GAP RIBBED NEATDEK

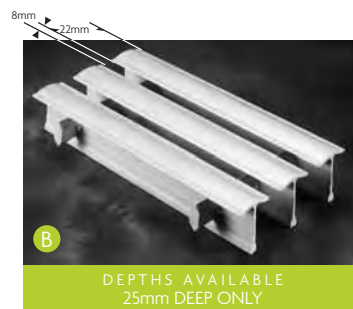

N-I BAR & NEATDEK 188

- D** RIBBED N-I BAR
- E** NEATDEK 188*



OPEN GRILLE FLOORING

- F** 3mm PLAIN
OPEN GRILLE FLOORING
- G** 3mm SERRATED
OPEN GRILLE FLOORING
- H** 5mm PLAIN
OPEN GRILLE FLOORING
- I** 5mm SERRATED
OPEN GRILLE FLOORING

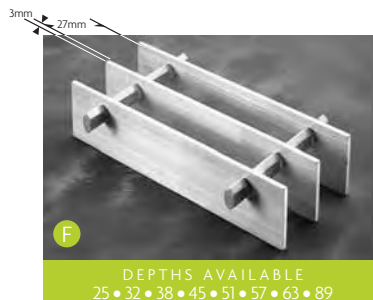

* please contact our head office for further details on this product

Panel Specification

All load-bearing bars: Aluminium Alloy 6082 T6

All swage bars: Aluminium Alloy 6082 T4

NEATDEK

NEATDEK aluminium alloy decking panels incorporating the patented neaco swage locking principle and providing a larger contact area than orthodox open grille flooring.

8mm Gap NEATDEK provides 74% contact area.
5mm Gap NEATDEK provides 84% contact area.

The flooring enjoys the advantages of traditional open grille flooring by allowing drainage for liquids and providing sunshading.

N-I BAR

N-I BAR aluminium alloy decking panels incorporating the swage locking principle for a handsome, lightweight and structurally efficient open grille panel. N-I BAR achieves a high strength to weight ratio and is available as standard with a ribbed or serrated surface. The 6.5mm bar has a 21% contact surface area which is larger than that offered by traditional flooring.

OPEN GRILLE FLOORING PANELS

The panels are available with a plain or serrated top surface.

Serrated Option

The serrated panels provide a positive anti-slip surface across the entire surface to suit the most demanding of situations.

neaco's Serrated Flat Bar achieved the highest rating (R13) when tested for slip resistance in accordance with DIN 51 130.

To achieve this rating the flooring surface must maintain a non-slip condition at an angle in excess of 35°.

neaco open grille flooring uses traditional rectangular load-bearing bars secured into position by the neaco swage locking process.

The rectangular load bars are available in 3.2mm and 4.8 widths.

All panels are available in lengths up to 7.3m.

PANEL WIDTHS

Number of load bearing Bars	Open Grille Flooring		N-I BAR	NEATDEK	
	3mm Bars	5mm Bars		8mm Gap	5mm Gap
2	35	36	38	53	56
3	65	66	68	84	87
4	95	96	98	114	117
5	125	127	128	144	147
6	156	157	158	174	177
7	186	187	189	205	208
8	216	217	219	235	238
9	246	248	249	265	268
10	276	278	279	295	298
11	307	308	309	326	329
12	337	338	340	356	359
13	367	369	370	386	389
14	397	399	400	416	419
15	427	429	430	447	450
16	458	459	461	477	480
17	488	490	491	507	510
18	518	520	521	537	540
19	548	550	551	568	571
20	578	580	581	598	601
21	609	611	612	628	631
22	639	641	642	658	661
23	669	671	672	689	692
24	699	701	702	719	722
25	729	732	732	749	752
26	760	762	763	779	782
27	790	792	793	810	813
28	820	822	823	840	843
29	850	853	853	870	873
30	880	883	883	900	903
31	911	913	914	931	934
32	941	943	944	961	964
33	971	974	974	991	994
34	1001	1004	1004		

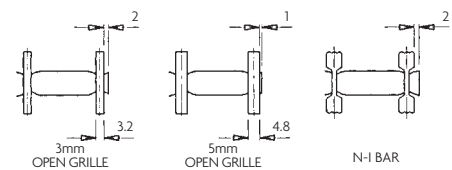

Tabulated panel widths are measured over the load-bearing bars.
Tolerance is +0mm, -3mm.
The swage bars extend through the load bearing bars as shown right.



Techdek Walkways

Load/span table

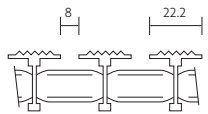
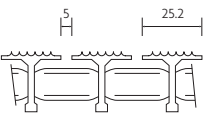
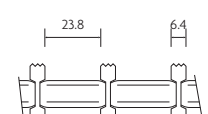
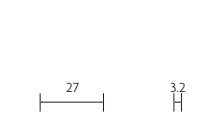
Maximum clear span (mm)

PANEL TYPE		Pedestrian loading categories as described in BS 4592 part one: 1995		LIGHT DUTY Access limited to one person 3kN/m ² U.D.L.				GENERAL DUTY Regular two-way pedestrian traffic. 5kN/m ² U.D.L.				HEAVY DUTY High density pedestrian traffic. 7.5kN/m ² U.D.L.				
		WEIGHT Kg/M ²	BAR HEIGHT	PLAIN BAR		SERRATED		PLAIN BAR		SERRATED		PLAIN BAR		SERRATED		
				1/200 SPAN OR 10mm	6.5mm	1/200 SPAN OR 10mm	6.5mm	1/200 SPAN OR 10mm	6.5mm	1/200 SPAN OR 10mm	6.5mm	1/200 SPAN OR 10mm	6.5mm	1/200 SPAN OR 10mm	6.5mm	
	8mm GAP RIBBED NEATDEK	11.0	25	*1100				1080				940				
		12.0	32	*1470	<i>1410</i>			1320	<i>1310</i>			1150				
		13.0	38	1830	<i>1650</i>			1540	<i>1480</i>			1350	<i>1340</i>			
		19.6	51	2360	<i>2120</i>			2070	<i>1860</i>			1830	<i>1680</i>			
	5mm GAP RIBBED NEATDEK	8.4	19	*700				*700				700				
		13.0	25	1180				1140			1000					
		15.8	38	1850	<i>1750</i>			1640	<i>1550</i>			1430	<i>1400</i>			
		20.9	51	2460	<i>2220</i>			2180	<i>1950</i>			1960	<i>1760</i>			
	N-I BAR	9.9	25	*1050		*700		1050		*700		920		*700		
		13.0	32	*1500	<i>*1440</i>	*1080		1340	<i>1330</i>	*1080		1170		940		
		14.0	38	1870	<i>*1690</i>	*1550	<i>1380</i>	1580	<i>1500</i>	1370	<i>1350</i>	1380	<i>1360</i>	1200		
		16.4	51	2300	<i>2070</i>	2120	<i>1820</i>	2030	<i>1820</i>	1820	<i>1680</i>	1780	<i>1640</i>	1600	<i>1510</i>	
	3mm FLAT BAR	9.2	25	*840		*650		*840		*650		800		*650		
		11.0	32	*1180		*960		1140		*960		1000		870		
		13.0	38	*1560	<i>1460</i>	*1310		1360	<i>1350</i>	1220		1200		1070		
		14.7	45	*1890	<i>1700</i>	*1700	<i>1560</i>	1600	<i>1520</i>	1450	<i>1410</i>	1400	<i>1370</i>	1270		
		16.7	51	2020	<i>1800</i>	1980	<i>1780</i>	1820	<i>1680</i>	1680	<i>1580</i>	1600	<i>1520</i>	1470	<i>1420</i>	
		18.4	57	2220	<i>2020</i>	2190	<i>1970</i>	2040	<i>1830</i>	1910	<i>1730</i>	1800	<i>1680</i>	1670	<i>1560</i>	
		20.3	63	2500	<i>2260</i>	2390	<i>2140</i>	2200	<i>1980</i>	2100	<i>1890</i>	2000	<i>1800</i>	1870	<i>1700</i>	
		27.9	89	3200	<i>2900</i>	3100	<i>2800</i>	2840	<i>2550</i>	2740	<i>2450</i>	2550	<i>2300</i>	2450	<i>2200</i>	
	5mm FLAT BAR	10.3	19	*675				*675				*675				
		13.0	25	*1030		*800		*1030		*800		910		760		
		15.7	32	*1450	<i>1400</i>	*1180		1305	<i>1300</i>	1140		1140		990		
		18.4	38	1860	<i>1680</i>	*1600	<i>1500</i>	1560	<i>1500</i>	1400	<i>1370</i>	1370	<i>1360</i>	1220		
		21.1	45	2120	<i>1900</i>	1970	<i>1770</i>	1830	<i>1680</i>	1640	<i>1560</i>	1590	<i>1520</i>	1450	<i>1410</i>	
		24.2	51	2340	<i>2100</i>	2200	<i>1980</i>	2060	<i>1860</i>	1920	<i>1740</i>	1820	<i>1680</i>	1680	<i>1570</i>	
		26.9	57	2560	<i>2300</i>	2420	<i>2180</i>	2260	<i>2030</i>	2130	<i>1910</i>	2040	<i>1830</i>	1900	<i>1730</i>	
		29.6	63	2780	<i>2500</i>	2640	<i>2370</i>	2440	<i>2200</i>	2320	<i>2080</i>	2200	<i>1980</i>	2100	<i>1880</i>	

BOLD The figures in bold show the maximum clear span for the category of loading whilst limiting the deflection to 1/200 of the clear span or 10mm, whichever is the lesser.

* Indicates that the clear span has been reduced further to allow for the effect of a 1kN concentrated load over an area 300mm x 300mm placed at the edge of the panel.

Italics Where spans exceed 1300mm and pedestrian comfort is of paramount importance, the table provides details of clear spans which produce deflections of 6.5mm.

Serration Weight The tabulated weight should be reduced by 0.7 Kg/m²

Techdek Walkways

Stair treads/options

Stairtread maximum lengths have been calculated based on a simply supported condition with application of a 4.5kN concentrated load over an area 150mm square placed at the centre of the front edge of the tread.

The maximum deflection is limited to $1/200$ of the effective span or 6mm, whichever is the lesser.

* For tread lengths of 1500mm and greater, the tread has been designed to support the application of a 4.5kN load whilst limiting deflection to 6mm.

Coloured nosings available.

NEATDEK

HEIGHT of Load Bearing Bar	MAX TREAD LENGTH	
	8mm Gap	5mm Gap
32mm	1150	N/A
38mm	1200	1250
51mm	1450	1500

No. of Bearing Bars	TREAD WIDTH 8mm & 5mm Gap
9	274
10	304
11	334
12	364
13	394
14	424
15	454

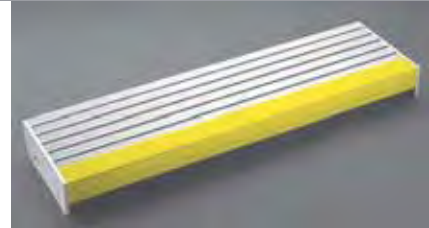

8mm GAP RIBBED NEATDEK

N-I BAR

HEIGHT of Load Bearing Bar	MAX TREAD LENGTH	
	Ribbed	Serrated
32mm	1050	950
38mm	1200	1075
51mm	1400	1300

No. of Bearing Bars	TREAD WIDTH
9	270
10	300
11	330
12	360
13	390
14	420
15	450

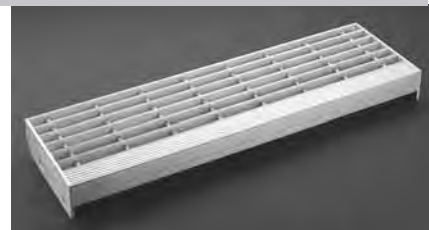

RIBBED N-I BAR TREAD

OPEN GRILLE FLOORING PANELS

HEIGHT of Load Bearing Bar	MAX TREAD LENGTH	
	Plain	Serrated
32mm	1050	1000
38mm	1200	1100
51mm	1450	1400

No. of Bearing Bars	TREAD WIDTH
9	270
10	300
11	330
12	360
13	390
14	420
15	450

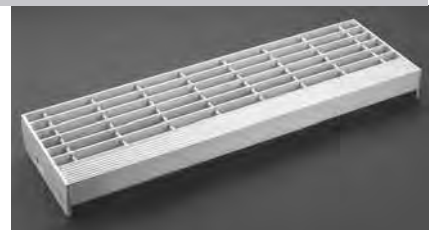

5mm PLAIN BAR TREAD

5mm SERRATED BAR TREAD

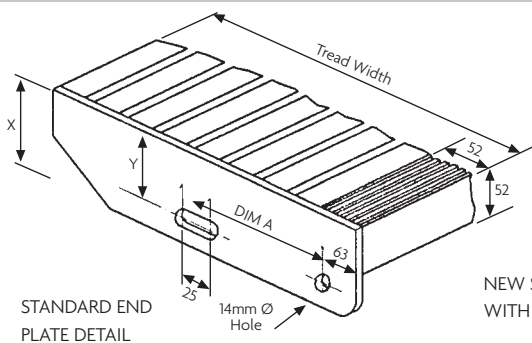
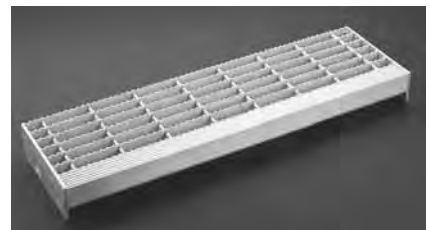

NEW STAIR NOSING IN ACCORDANCE WITH BS 8300 : 2009.

Tread Width mm	Dim. A mm
250-350	120
351-460	212

Height of Load Bearing Bar	Dim. x	Dim. y
32,38	75	55
51	100	80



Photographed in 2011 - all installed in 1991

frequently asked questions

Q Do you provide curved rails?

A Yes, we can provide rolled tube to radius or template.

Q Castings and tubes seem dissimilar in colour - why is that?

A One is cast aluminium, the other is extruded aluminium - they will blend over time as the extruded tube dulls (see pictures on this page)

Q I need a DDA compliant rail - is aluminium warm to the touch?

A Yes, if specified with coating we have rail systems to comply with DDA requirements.

Q Are structural fixings supplied?

A These can be supplied subject to your specification at extra cost.

Q Does the system rust or corrode?

A No. It is aluminium. Aluminium oxidizes with age.

Q Do I need to allow for expansion?

A Yes, please allow expansion joints after each 6 metre length if external.

Q Do you supply kicking flat?

A Yes, fixed to open grille aluminium flooring or railing system. Please specify your requirements.

Q Does the system require ongoing maintenance?

A No, an annual routine inspection of structural fixings for damage will suffice.

Q Can I extend or modify the rail system at a later date?

A Yes, all our systems are based on modular components.

Q Is the product recyclable?

A Yes, Genesis is fully recyclable and as it's aluminium the material retains a high residual value.

...quality that lasts

Installed 1985 (photographed 2001)



Lighthouse, northern coastline

Installed 1986 (photographed 2011)



Tadcaster Water Treatment Works

Installed 1991 (photographed 2011)



Headingly Water Treatment Works

